

BMI26x, BMI270, BMI32x Family Inertial Measurement Units

Handling, Soldering And Mounting Instruction



HSMI for BMI2xy/BMI32x IMUs

Document revision	1.1
Document release date	February 2022
Document number	BST-MIS-HS001-03
Sales Part Number(s)	0 273 017 000, 0 273 017 001, 0 273 017 008, 0 273 017 010, 0 273 017 018, 0 273 017 028

Notes Data and descriptions in this document are subject to change without notice. Product photos and pictures are for illustration purposes only and may differ from the real product appearance. The technical details and legal disclaimer of the respective product data sheet apply.

1 Purpose of this document

This document describes the recommended conditions and parameters to be applied when handling, soldering and mounting Bosch Sensortec's Inertial Measurement Units (IMUs) to a PCB. This document applies to all mentioned Sales Part Numbers mentioned on the cover sheet. In case the Sales Part Number of your Bosch Sensortec device is not listed, please contact your Bosch Sensortec representative.

Important:

- ▶ In order to avoid any damages of the sensor and resultant loss of warranty please strictly keep with the instructions described within this document
- ▶ It is also strongly recommended to study the sensor data sheet prior to handling the sensor device
- ▶ In case you have any other questions, please do not hesitate to contact your Bosch Sensortec representative for further advice

Table of Contents

1 Purpose of this document	2
2 Package outline	5
3 Landing pattern	5
4 Moisture sensitivity level (MSL)	5
5 RoHS compliancy / halogen content	5
6 Mounting recommendations	5
6.1 Recommendations in detail	6
6.2 Recommendation details.....	7
6.2.1 Push-button contacts.....	7
6.2.2 Thermal hot-spots on the PCB	8
6.2.3 Redundant PCB anchor points	8
6.2.4 Mechanical stress maximum on the PCB.....	9
6.2.5 Distance to PCB anchor points.....	9
6.2.6 Vibrating PCB	10
6.3 Resin coatings.....	10
7 Note on internal package structures	11
8 Device marking	11
9 Reflow soldering	11
9.1 Recommendation for soldering of sensors in LGA package	11
9.2 Classification reflow profiles	12
9.3 Multiple reflow soldering cycles.....	12
10 Tape & reel	13
10.1 Tape & reel specification	13
10.2 Orientation within the reel.....	13
11 Further important mounting, assembly & handling recommendations	14
12 Document history and modification	15

List of figures

Figure 1: Push-button contacts	7
Figure 2: Thermal hot-spots on the PCB.....	8
Figure 3: Redundant PCB anchor points	8
Figure 4: Mechanical stress maximum on the PCB	9
Figure 5: Distance to PCB anchor points	9
Figure 6: Vibrating PCB.....	10
Figure 7: Resin coatings.....	10
Figure 8: Recommendation to keep the side of LGA free from solder material.....	11
Figure 9: Recommendation not to use underfill for LGA packages	12

2 Package outline

Please refer to the latest version of the corresponding product datasheet or preliminary datasheet.

3 Landing pattern

Please refer to the latest version of the corresponding product datasheet or preliminary datasheet.

4 Moisture sensitivity level (MSL)

The moisture sensitivity level of the device corresponds to JEDEC Level 1, see also

- ▶ IPC/JEDEC J-STD-020E "Joint Industry Standard: Moisture/Reflow Sensitivity Classification for non-hermetic Solid State Surface Mount Devices"
- ▶ IPC/JEDEC J-STD-033D "Joint Industry Standard: Handling, Packing, Shipping and Use of Moisture/Reflow Sensitive Surface Mount Devices"

Both documents are available on [JEDEC's website](#).

The sensor fulfils the lead-free soldering requirements of the above-mentioned IPC/JEDEC standard, i.e. reflow soldering with a peak temperature T_p up to 260°C.

5 RoHS compliancy / halogen content

The sensors meet the requirements of the EC restriction of hazardous substances (RoHS) directive, see also:

RoHS-Directive 2011/65/EU and its amendments, including the amendment 2015/863/EU on the restriction of the use of certain hazardous substances in electrical and electronic equipment.

The devices (Sales Part Numbers) as listed on the cover sheets are also halogen-free. For more details on the corresponding analysis results please contact your Bosch Sensortec representative.

Corresponding chemical analysis certificates are available as separate documents from Bosch Sensortec.

6 Mounting recommendations

MEMS sensors in general are high-precision measurement devices, which consist of electronic as well as mechanical silicon structures. Bosch Sensortec MEMS sensor devices are designed for precision, efficiency, and mechanical robustness.

However, to achieve best possible results for your design, the following recommendations should be taken into consideration when mounting the sensor on a printed circuit board (PCB).

The scenarios described below –given as examples– may lead to a bending of the PCB, which as a consequence, might influence the performance of the sensor mounted on the PCB.

In order to evaluate and to optimize the considered placement position of the sensor on the PCB it is recommended to use additional tools during the design in phase, e.g.:

- ▶ regarding thermal aspects: infrared camera
- ▶ regarding mechanical stress: warpage measurements and/or FEM-simulations
- ▶ regarding shock robustness: drop tests of the device after soldering on the target application PCB

6.1 Recommendations in detail

- ▶ It is generally recommended to keep a reasonable distance between the sensor mounting location on the PCB and the critical points described in the following examples. The exact value for a “reasonable distance” depends on many customer specific variables and must therefore be determined case by case.
- ▶ It is generally recommended to minimize the PCB thickness (recommended: ≤ 0.8 mm), since a thin PCB shows less intrinsic stress, e.g. while being bent.
- ▶ It is not recommended to place the sensor directly under or next to push-button contacts as this can result in mechanical stress.
- ▶ It is not recommended to place the sensor in direct vicinity of extremely hot spots regarding temperature (e.g. a μ Controller or a graphic chip) as this can result in heating-up the PCB and consequently also the sensor nearby.
- ▶ It is not recommended to place the sensor in direct vicinity of a mechanical stress maximum (e.g. in the center of a diagonal crossover, refer to 6.2.4). Mechanical stress can lead to bending of the PCB and also of the sensor, nearby.
- ▶ Do not mount the sensor too closely to a PCB anchor point, where the PCB is attached to a shelf (or similar) as this could also result in mechanical stress. To reduce potential mechanical stress, minimize redundant anchor points and/or loosen respective screws (refer to 6.2.3).
- ▶ It is not recommended to mount the sensor in areas where resonant amplitudes (vibrations) of the PCB are likely or to be expected.
- ▶ Please avoid partial coverage of the sensor by any kind of (epoxy) resin, as this can possibly result in mechanical stress.
- ▶ Avoid mounting (and operation) of the sensor in the vicinity of strong electric and/or strong infrared radiation fields (IR).
- ▶ Avoid mounting (and operation) of the sensor in strong radio frequency environments.
- ▶ When used together with a magnetometer, avoid mounting (and operation) of the sensor in the vicinity of strong magnetic fields
- ▶ Avoid electrostatic charging of the sensor and of the device wherein the sensor is mounted.
- ▶ Avoid mounting the sensor to flexible PCB substrates.

- ▶ Other component selection (e.g. MLCC/inductors etc.) and their placement in vicinity to IMUs on the target PCB needs to be finalized based on FEM simulations and tests (e.g. vibration analysis). During design-in, it is recommended to analyze vibrations on test PCBs to further optimize the placement position of the IMU and surrounding components on target PCB

In case you have any questions with regard to the mounting of the sensor on your PCB, or with regard to evaluate and/or to optimize the considered placement position of the sensor on your PCB, do not hesitate to contact us. If the above mentioned recommendations cannot be realized appropriately, a specific in-line offset-calibration after placement of the device onto your PCB might help to minimize potentially remaining effects.

6.2 Recommendation details

6.2.1 Push-button contacts

Keep a reasonable distance to push-button contacts, when placing the sensor device. Do not position the sensor directly beneath a push-button contact.

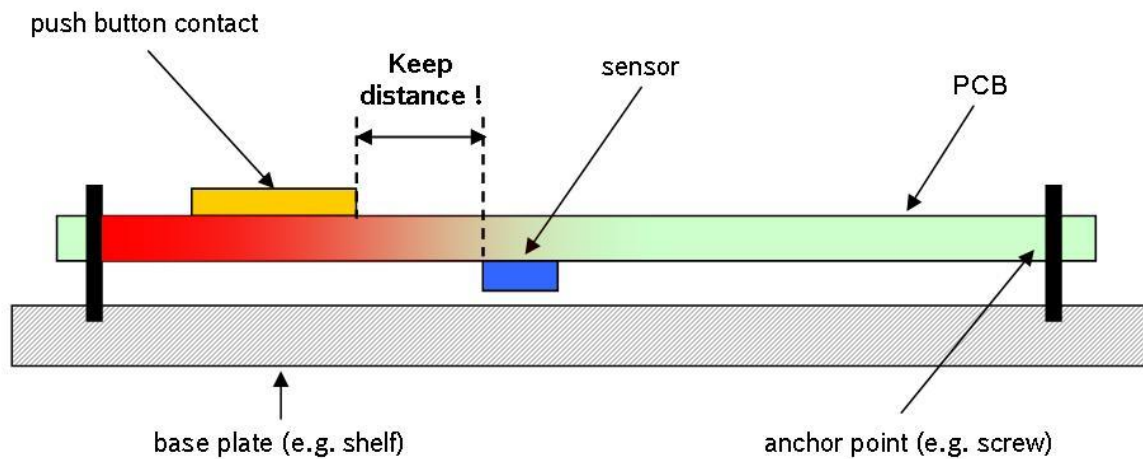

Figure 1: Push-button contacts

6.2.2 Thermal hot-spots on the PCB

Keep a reasonable distance from any thermal hot spots, when placing the sensor device. Hot spots can for example be other integrated circuits with high power consumption.

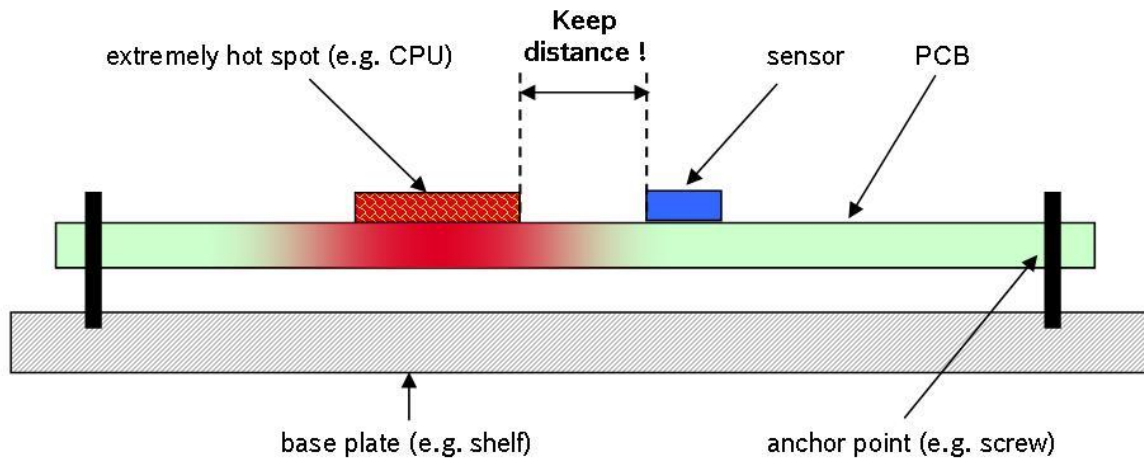

Figure 2: Thermal hot-spots on the PCB

6.2.3 Redundant PCB anchor points

It is recommended to unscrew or remove any redundant PCB anchor points. In theory, an ideal flat plane is determined by 3 anchor points, exclusively. Any further anchor point will over-determine the ideal flat plane criteria. If these redundant anchor points are out of plane position (which means not 100% exact in plane position) the ideal flat criteria is infringed, resulting in mechanical stress.

The below given figure describes an expected stress maximum in the center of the diagonal crossover, assuming that the 4 anchor points are not 100% exact in plane (over-determined ideal flat plane criteria). Unscrewing or removing one of the redundant anchor points can minimize mechanical stress, significantly.

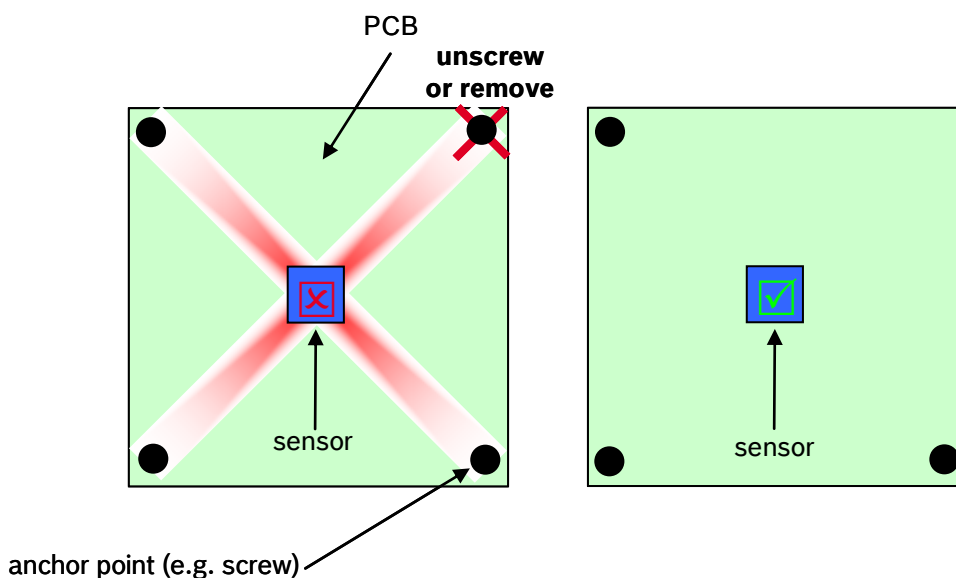

Figure 3: Redundant PCB anchor points

6.2.4 Mechanical stress maximum on the PCB

It is recommended to keep a reasonable distance from any mechanical stress maximum, when placing the sensor device. Mechanical stress can be induced for example by redundant anchor points, as described in 6.2.3.

The below given example will show a stress maximum in the center of the diagonal crossover of the 4 anchor points. It is good manufacturing practice to always avoid or reduce the mechanical stress by optimizing the PCB design first, then to place the sensor in an appropriate low stress area.

Best practice is to place MEMS components on the PCB in locations where the stress value is not exceeding 500 μ strain.

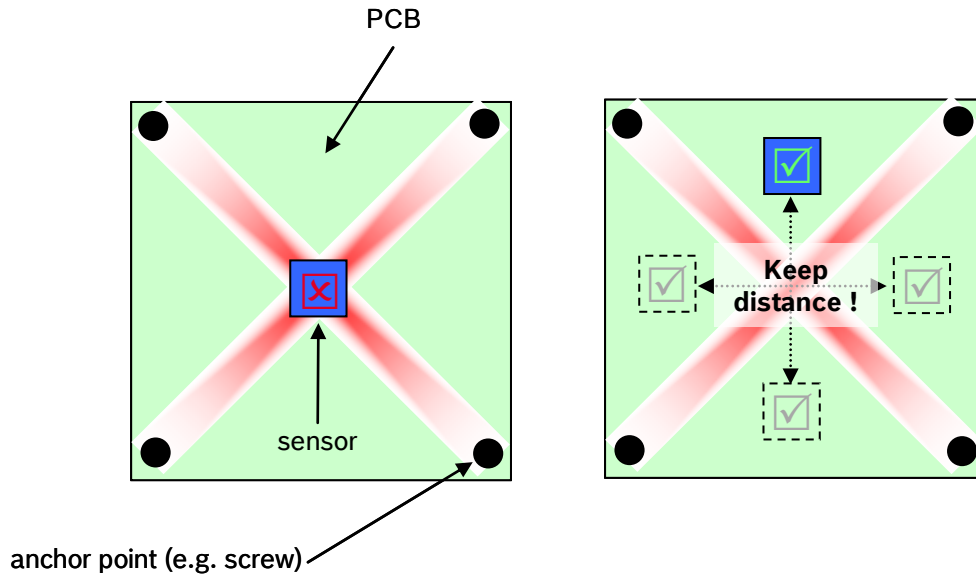

Figure 4: Mechanical stress maximum on the PCB

6.2.5 Distance to PCB anchor points

Please keep a reasonable distance from any anchor points, where the PCB is fixed at a base plate (e.g. like a shelf or similar), when placing the sensor device.

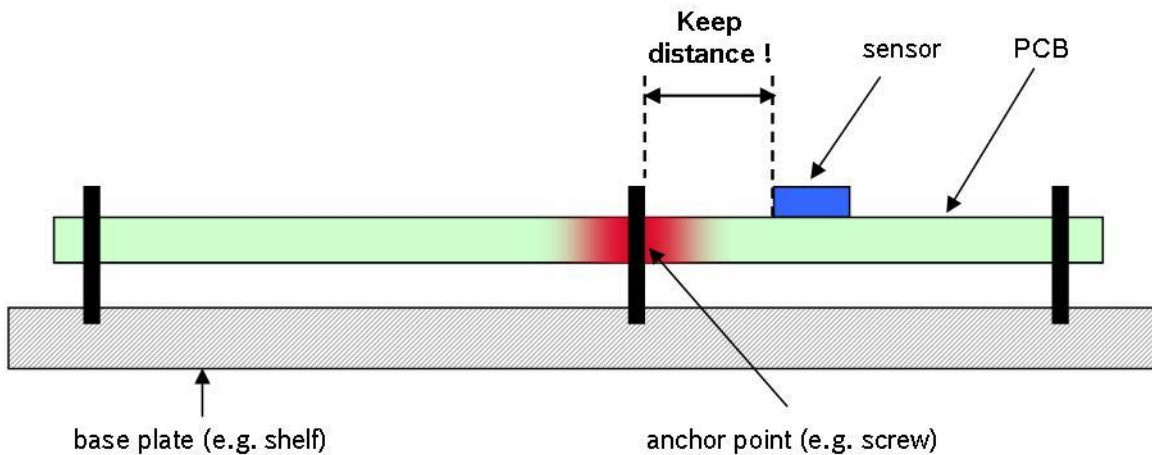

Figure 5: Distance to PCB anchor points

6.2.6 Vibrating PCB

Do not place the sensor next to components or in areas where resonant amplitudes (vibrations) of the PCB are likely to occur or to be expected. External vibrations with high frequencies (>20kHz) can disturb the sensor output signals or permanently damage the sensor element.

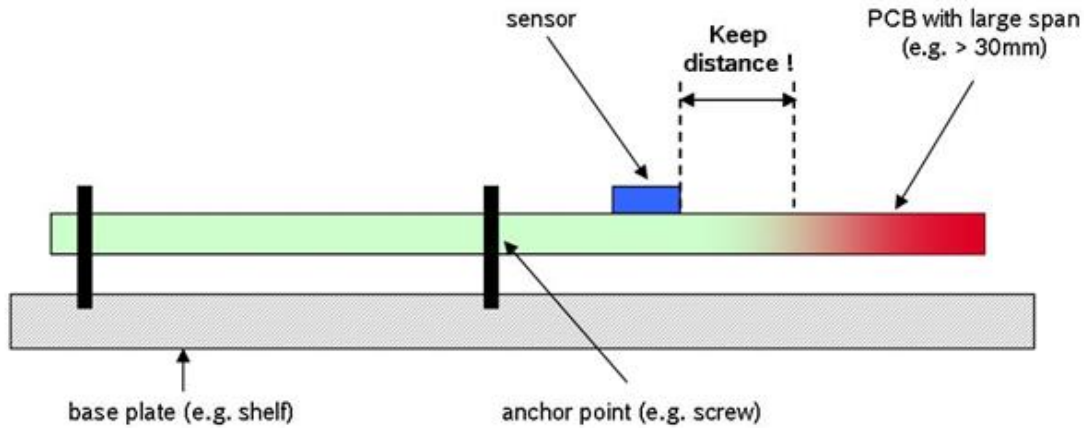

Figure 6: Vibrating PCB

6.3 Resin coatings

Please avoid partial covering of the sensor with any protective material like for example epoxy resin.

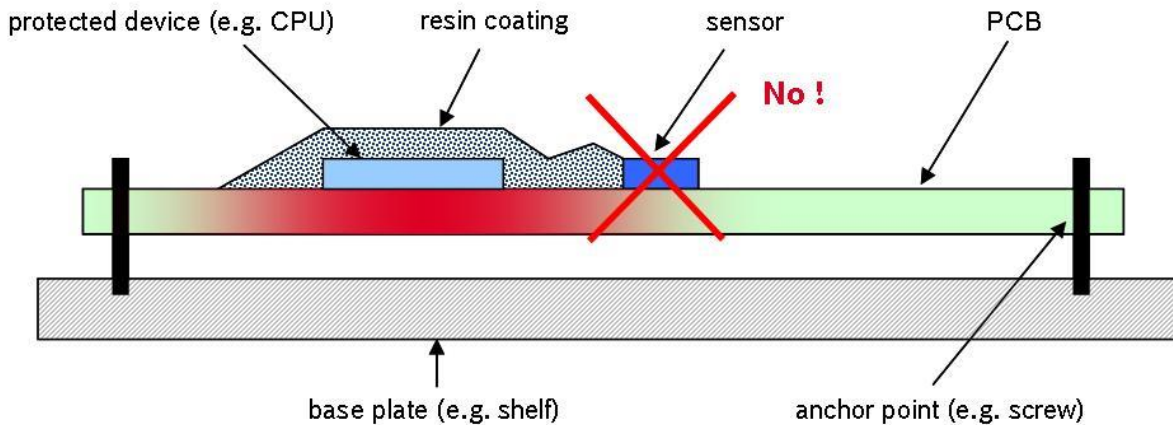

Figure 7: Resin coatings

As shown in the above figure, please take care that the sensor (if at all) is not only partially covered and also not in contact with any (epoxy) resin material leading to an un-symmetric stress distribution over the sensor package.

7 Note on internal package structures

Within the scope of Bosch Sensortec's ambition to improve its products and secure the product supply while in mass production, Bosch Sensortec qualifies additional sources for the LGA package of its sensors.

While Bosch Sensortec took care that all of the technical package parameters as described above are 100% identical for both sources, there can be differences in the chemical analysis and internal structural between the different package sources.

However, as secured by the extensive product qualification processes at Bosch Sensortec, this has no impact on the usage or the quality of the sensor.

8 Device marking

Please refer to the latest version of the corresponding product data sheet or preliminary data sheet.

9 Reflow soldering

9.1 Recommendation for soldering of sensors in LGA package

Please ensure that the edges of the LGA substrate of the sensor are free of solder material. It is not recommended to allow solder material forming a high meniscus covering the edge of the LGA substrate (compare figure below).

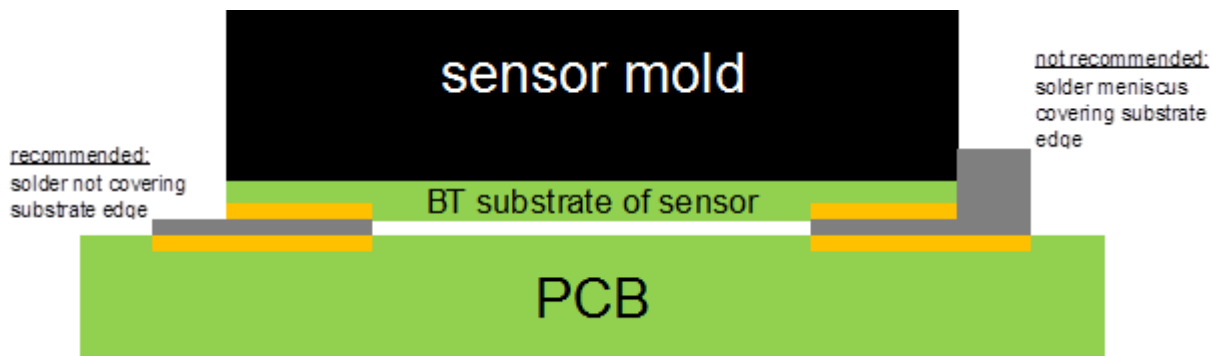

Figure 8: Recommendation to keep the side of LGA free from solder material

Using copper underfill for the LGA package is forbidden, compare figure below.

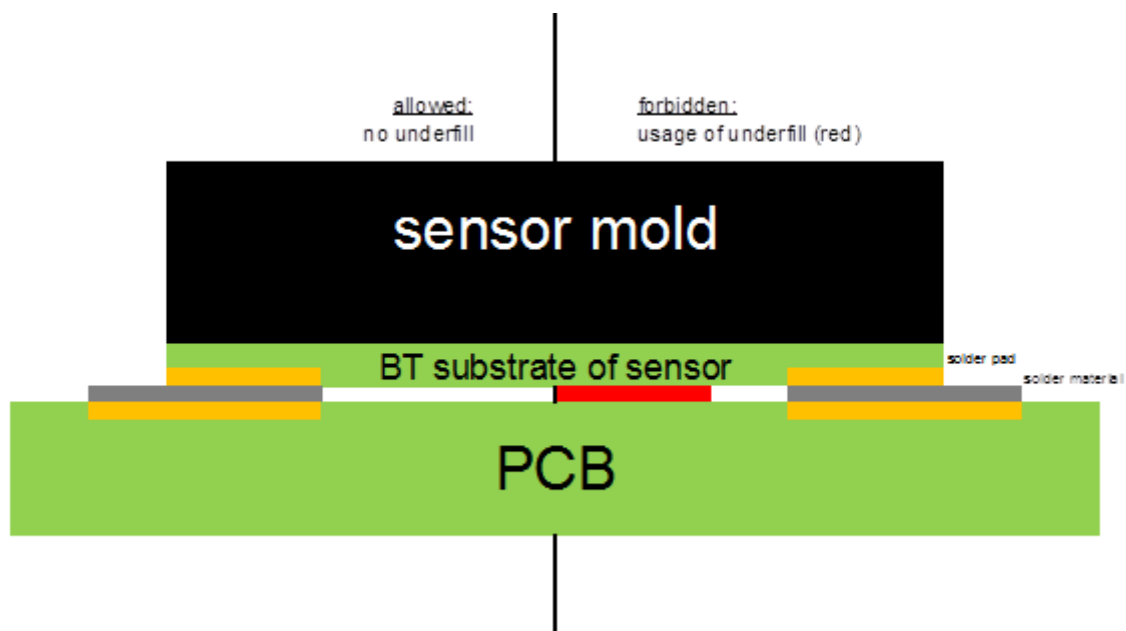

Figure 9: Recommendation not to use underfill for LGA packages

9.2 Classification reflow profiles

The sensor fulfils the JEDEC and lead-free soldering requirements described in chapter 4, i.e. reflow soldering (after MSL1 pretreatment) with a peak temperature T_p up to 260°C.

9.3 Multiple reflow soldering cycles

The product can withstand in total up to 3 reflow soldering cycles. In case 5 cycles are required, please contact your local Bosch Sensortec representative.

This could be a situation where a PCB is mounted with devices from both sides (i.e. 2 reflow cycles necessary) and where in the next step an additional re-work cycle could be required (1 reflow).

10 Tape & reel

10.1 Tape & reel specification

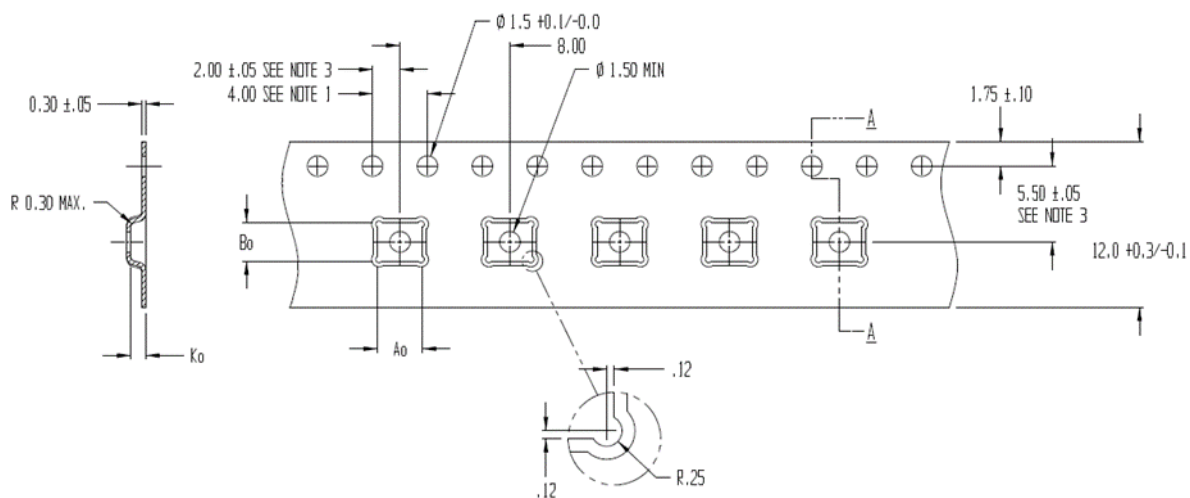

$$A_0 = 3.30, B_0 = 2.80, K_0 = 1.10$$

Note:

- ▶ Tolerances unless noted: ± 0.1
- ▶ Sprocket hole pitch cumulative tolerance ± 0.1
- ▶ Camber in compliance with EIA481
- ▶ Pocket position relative to sprocket hole measured as true position of pocket, not pocket hole
- ▶ A_0 and B_0 are calculated on a plane at a distance "R" above the bottom of the pocket

10.2 Orientation within the reel

→ Processing direction →

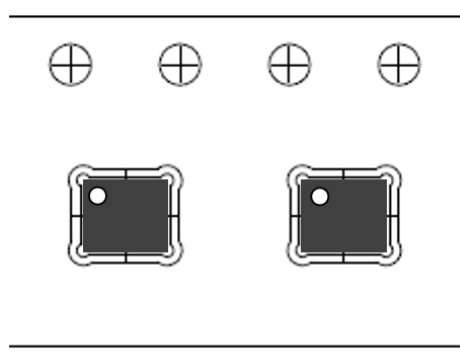

11 Further important mounting, assembly & handling recommendations

Bosch Sensortec's IMUs are designed to sense acceleration and rate of rotation with high accuracy even at low amplitudes and contain highly sensitive structures inside the sensor element. The MEMS sensor can tolerate mechanical shocks up to several thousand g's. However, these limits might be exceeded in conditions with extreme shock loads such as e.g. hammer blow on or next to the sensor, dropping of the sensor onto hard surfaces etc.

We strongly recommend to avoid any g-forces beyond the limits specified in the data sheet during transport, handling and mounting of the sensors in a defined and qualified installation process.

The IMUs have built-in protections against high electrostatic discharges or electric fields (2kV HBM); however, anti-static precautions should be taken as for any other CMOS component.

Unless otherwise specified, proper operation can only occur when all terminal voltages are kept within the supply voltage range. Unused inputs must always be connected to a defined logic voltage level.

Ultrasonic cleaning and welding is not recommended.

12 Document history and modification

Rev. No	Chapter	Description of modification/changes	Date
0.5	-	Document creation	3 Apr 2018
0.5.1	Cover	Updated Part#	18 Sep 2018
	9.2	Updated Table + Graphic	
	10	Spec, Graphic + Definition included	
0.5.2		Document name change to MIS-HS001	28 Nov 2018
1.0	Cover	Included Part# 0.273.017.003, -.004, -.008	09 Oct 2019
	4	Updated to latest JEDEC STD	
	5	Sentence rephrased	
	6.2.6	Updated content	
	9.2	Shortened content	
	11	Sentence rephrased Updated Legal Disclaimer	
1.1	All	Updated template	17 Feb 2022
	Cover	Legal Disclaimer replaced by reference page 1 "Notes"	
	Cover	Included BMI32x, Part# 0 273 017 018, 0 273 017 028	
	Cover	Excluded Part# 0 273 017 002, 0 273 017 003, 0 273 017 004 (EOL)	
	1	Sentence rephrased	
	5	Updated directive	
	6.1	Radio frequency environments + other components included	
	6.2.4	Updated content	
	9.3	5 cycles included	
	11	Sentence rephrased	

Bosch Sensortec GmbH
Gerhard-Kindler-Straße 9
72770 Reutlingen / Germany

contact@bosch-sensortec.com
www.bosch-sensortec.com

Modifications reserved
Specifications subject to change without notice
Document number: BST-MIS-HS001-03